

# TAKEX TRIPLE MIRROR PASSIVE SENSOR

## PIR-T40NAM (W)

### (Vertical curtain protection)

## Instruction Manual

Thank you for purchasing this product.  
Before using the product, please read this instruction manual to ensure correct operation.

## 1 PRODUCT DESCRIPTION

PIR-T40NAM (W) is passive infrared sensor that detects far-infrared rays emitted from the human body and outputs a contact signal. Since this unit significantly reduces lost and false detection using the unique triple mirror and signal processing systems, it can be used both for indoor and outdoor applications. This unit has the following features suitable for multiple applications.

- Detection distance up to 115'(40m) (Max 150'(45m) with high density mode)
- Detection distance and direction adjustable
- Mounting height of 6.6' to 13'(2 to 4m) for normal operation (max. 20'(6m) in specialized operation modes)
- Equipped with N.C. contact output for security and N.O. contact output for activation of ancillary devices
- Can be mounted on wall surfaces, as well as on poles, ceilings, and under eaves using the optional accessories (sold separately)
- Equipped with anti-masking and back tamper functions for more secure protection

## 2 PARTS DESCRIPTION

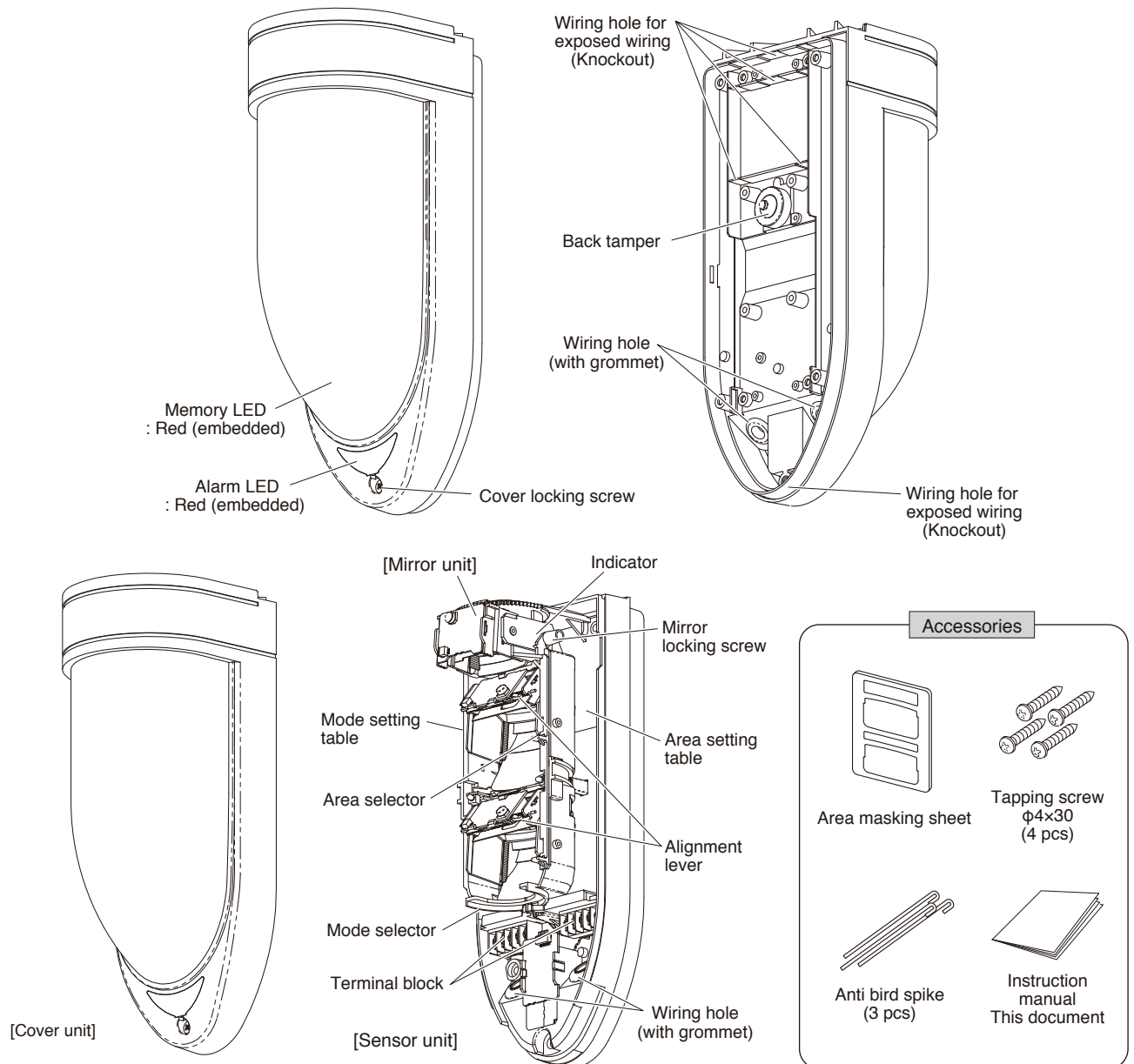

# 3 PRECAUTIONS

Be sure to observe

This manual describes precautions by classifying them based on degrees of danger and damage that would be generated if using the unit incorrectly.



## Warning

This indicates the possibility of severe injury, and even death, if ignored or a user handles the unit incorrectly.



## Caution

This indicates the possibility of minor injury and/or damage to properties, or of a notification delay in your system due to false operations and/or non-detection, if ignored or a user handles the unit incorrectly.

We categorize these precautions throughout the manual using the following symbols.



A prohibited action you must not do.



An action you must do, and information you should keep in mind



## Warning



Do not disassemble or modify the unit. Failure to follow this may result in fire, electric shock, and/or malfunction.



If the following errors/malfunctions occur, power off the unit immediately, and contact your dealer.

Failure to follow this may result in fire, electric shock, and/or malfunction.

- Smoke, abnormal odor, and/or sound are found
- Liquid, such as water, and/or foreign material has entered the unit
- The unit is deformed and/or parts are damaged



Do not install the unit in a place and/or with a mounting method that cannot support its weight. Failure to follow this may result in injury and/or property damage when the unit falls.



Mount the unit on a solid ceiling or wall surfaces where reinforcement materials are used. If you mount the unit on non-wood plaster board or concrete, securely mount it using anchors and mounting screws that match the wall materials. Failure to follow this may result in injury and/or property damage if the unit falls.



Do not use the unit with power voltage levels other than those specified. Failure to follow this may result in fire, electric shock, and/or malfunction.



Do not connect devices that exceed the indicated capacity to the output contact of the unit. Failure to follow this may result in electric shock, fire, and/or malfunction.



Do not touch terminals with wet hands. Failure to follow this may result in electric shock.



## Caution



Do not apply impact to the unit. Applying strong impact to the unit may result in performance deterioration and/or damage to the unit.



The unit may not operate properly near devices that generate a strong electric or magnetic field. Also, devices near the unit may not operate properly due to the magnetic field and/or magnetism generated from the unit. Make sure to check it before operation.



Make sure to perform sufficient operation checks on the whole system before operation.



Securely conduct installation work according to the instruction manual. Also, make sure to use the supplied accessories and specified components. Failure to follow this may result in injury and/or property damage in the event of fire or electric shock, if the unit falls.



Contact qualified personnel for any electrical work necessary for installation, if required. Failure to follow this may result in fire and/or electric shock.



Do not install the unit in places subject to oil smoke, steam, high humidity, and/or a lot of dust. Electricity transmitted through oil, water, and/or dust may result in fire, electric shock, and/or false operation.



Do not perform aerial wiring of power and signal cables. Failure to follow this may result in electric shock, fire, and/or malfunction.



Passive infrared sensors are designed to detect changes of far-infrared ray energy. Energy changes largely when the human body moves across the detection area. However, energy does not change greatly when the human body comes closer in a straight line, or stops.

In addition, if the detection area environment generates similar changes due to certain factors, the unit will issue an alarm without being able to judge properly.

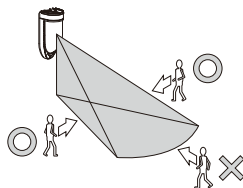

Set the area within the rated detection distance range according to the instruction manual. If you use the unit outside the specified range, an appropriate area will not have been configured, and the unit may operate unsteadily, and/or detection may fail.



Avoid installing the unit in the following places. Otherwise, false detection may occur.

- Places subject to strong direct or reflected light (sunlight, spotlight)
- Places subject to rapid temperature fluctuations (air outlets of air-conditioning equipment, etc.)
- Places where moving objects are included in the detection area (trees, branches and leaves, laundry, etc.)
- Places subject to strong vibration and/or electric noise
- Places where dogs, cats, birds, and/or automatic cleaning robots may pass
- Places where shielding objects (including glass and transparent resin, etc.) are included in the detection area (shading parts will not be detected)
- Places where the sensor part looks inclined from the front view (the area cannot be properly configured)
- Places that intruders can easily touch

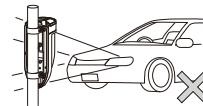

Strong light that hits the sensor

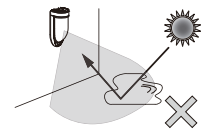

Sunlight reflection



Air outlets of air-conditioning equipment



Trees, branches and leaves, laundry

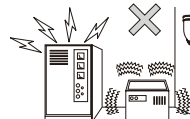

Strong vibration and/or electric noise

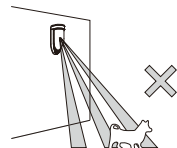

Pets, such as dogs, cats, and birds

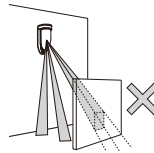

Shielding objects

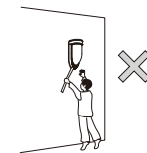

Places that people can easily touch

## ⚠ Caution

! Mount the unit straight so that it does not look inclined from the front and side view.

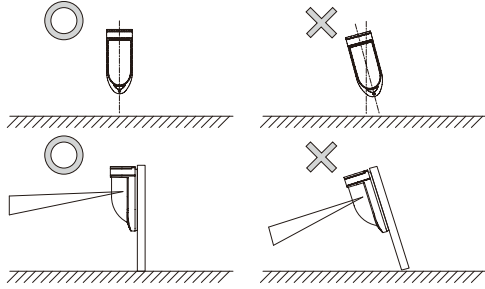

! Please pay attention that the detection distance changes by below factors  
 \* Mounting height  
 (The higher installation position, the longer detection distance becomes)  
 \* Inclination in the ground in detection area

The configuration of detection area based on the level ground. In case of inclined ground, the detection distance becomes long in the downslope, the detection distance becomes short in the upslope. And it is impossible to configure the proper detection area in where there are in inclined or stepped ground in detection area. There is a possibility that the false or lost detection occur under this situation. Please check the proper position in each detection zone using LED aiming function and do the operation check by walking test.

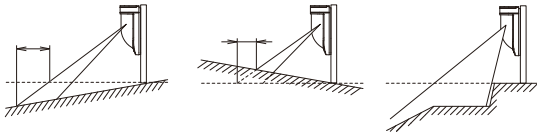

! In case of the detection along the wall, adjust the detection area by noting the following points.

• When mounting on the wall, adjust the detection area so that it does not cover the wall surface. It may cause false or lost detection. Move the detection area horizontally by one step or more to keep it away from the wall.

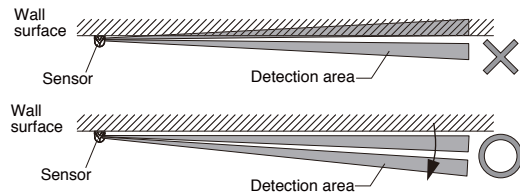

• Avoid operation in places where there is not enough space for the detection area to pass through without being obstructed. It may cause false or lost detection. When this operation is obliged, selecting "high density mode" is recommended.

Note, however, that the performance to prevent malfunction against environmental change and small animals will be reduced with this mode.

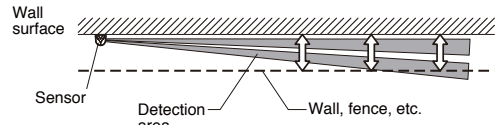

Perform the operation check after installation and also on periodic basis to make sure that there is no problem in the operation.

! Install the unit in the location where the detection area faces toward a place that intruders may pass through.

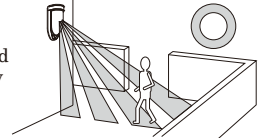

! Adjust the detection area so that it does not go beyond the site. (Unexpected objects may be detected)

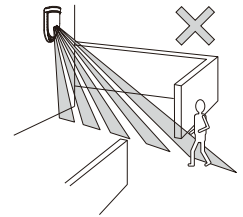

! After installation, make sure to adjust the detection area and perform sufficient operation check.

! Refer to the detection area chart, and select the installation location. Then, check the actual operation, and adjust the appropriate area.

! This unit has a rainproof structure, not a waterproof structure. Do not hose it directly. Do not use the unit in places subject to water and/or constant high humidity, such as bathroom. Failure to follow this could result in malfunction.

! In order to maintain the rainproof structure of this unit, mount it in the correct direction. Mounting it sideways or upside down may result in malfunction.

! Apply caulking to wiring holes based on the mounting wall material, if necessary, in order to maintain rainproof performance.

! This unit is for wall mounting. When installing it on poles, ceilings, or under eaves, use the specified attachments (sold separately).

# 4 DETECTION AREA

Mounting height : 2.0m  
 Detection distance : 40m

[Top view]

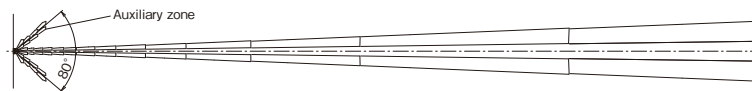

[Side view]

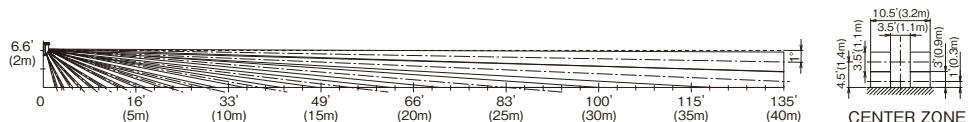

Mounting height : 2.0m  
 Detection distance : 20m

[Top view]

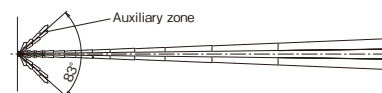

[Side view]

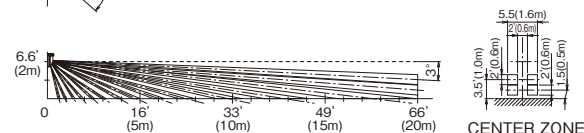

※ The right-and-left auxiliary zone in near detection area becomes effective when the area masking plate is removed.

※ Adjust the mounting height of the sensor using the center of the sensor housing as a guide.

## Near detection area

### ● Detecting near area

When detection of nearer area is required, remove "Area masking plate" stored inside so that the right-and-left auxiliary detection zone can function.  
Check the direction of auxiliary detection zone and the detecting performance for proper operation.

Remove all "Area masking plate" stored in 3 x reflection mirror inside the sensor unit.

\* Avoid soiling the mirror surfaces with dirt or fingerprint.

**!** To disable the auxiliary zone after removing "Area masking plate (x3)", replace them in the original positions. In that case, remove the adhesive, and replace "Area masking plate" in the positions of "F", "R" and "C", as indicated on the adjacent diagram. Each of the 3 "Area masking plates" are uniquely shaped so make sure to replace them correctly before operation.

[Top view]

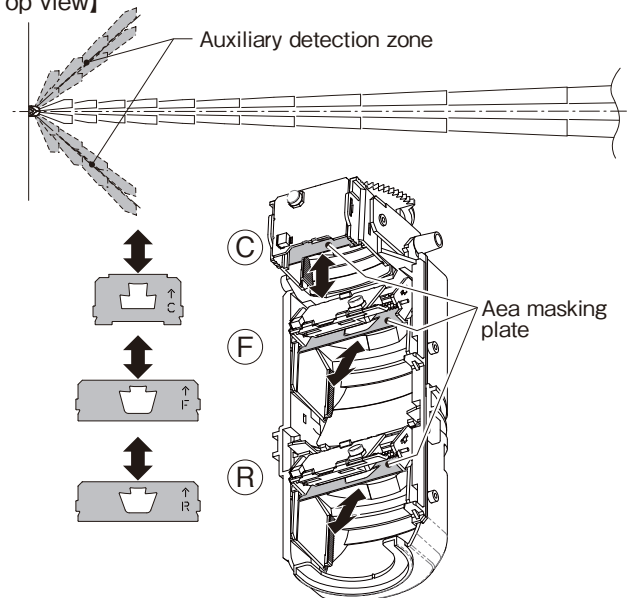

### ● Detecting area directly beneath the sensor

When detecting area directly under the sensor, select "ON" in DIP switch 8 (Creep zone detection setting) in Mode selector 1. Please note that the pet immunity performance decreases when this setting is enabled.

This setting is disabled in the high density mode. (Refer to "7. FUNCTION")

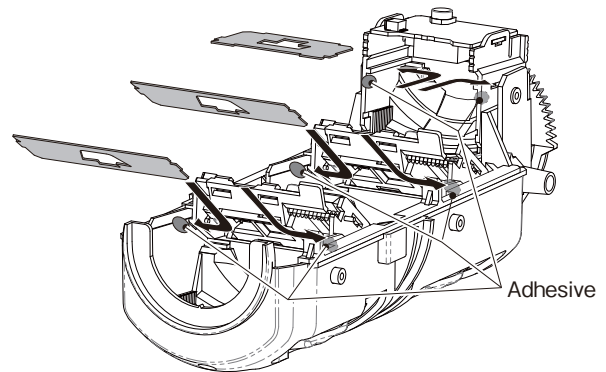

## Masking method of the detection area

### ● Detection area setting to less than 66'(20m)

When the detection area is adjusted to less than 66'(20m), set area selector to "66'(20m)" position and mask the detection area using the supplied area masking sheet, and set "ON" in the short distance setting (dip switch 5 in mode selector 2). (Refer to "7. FUNCTION", "8. ADJUSTMENT OF DETECTION AREA")

When masking each detection area from ① to ④, attach the area masking sheet to the surface of the mirror unit corresponding to the detection area as indicated with the arrow

\* Avoid soiling the mirror surfaces with dirt or fingerprint.

[Top view]

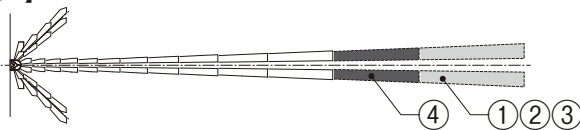

[Side view]

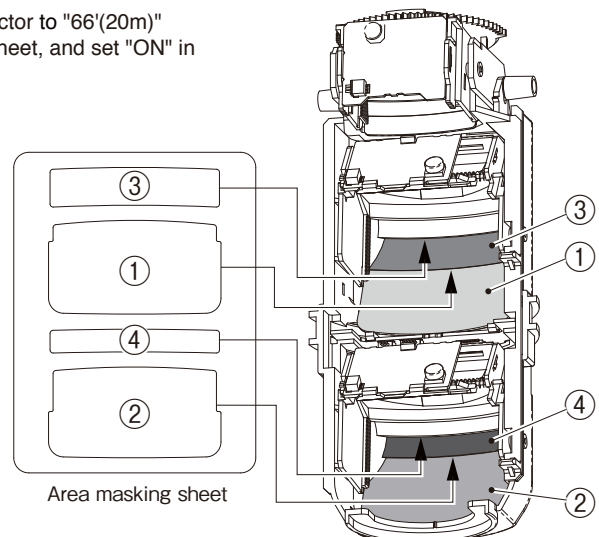
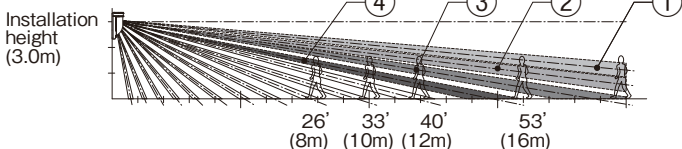

**!** Attach the area masking sheet in order (①→④) from the longest part of the detection area, and adjust the detection distance.

## Precautions on the detection area setting

### ● Detection area range

Since the detection zone extends until it hits the ground or wall surface, the unit may detect objects even in places beyond the specified distance. In order to avoid unexpected detection, adjust the area sufficiently.

### ● Detection area distance adjustment

When the detection area is adjusted to less than 66'(20m), please mask the detection area using the supplied area masking sheet.

(Refer to "8 ADJUSTMENT OF DETECTION AREA")

\* Attach the area masking sheet in order from the longest part of the detection area, and adjust the detection distance.

# 5 INSTALLATION



The mounting height and adjustable detection distance depend on the operation mode. Carefully check the operation mode and detection area setting before installation and area setting.

Use the unit with the correct operation mode setting. Select operation mode to use and perform the setting correctly. This unit can be operated from ① to ④ modes, as follows.

## ● Normal operation modes

Normal operation mode reduces the false detection caused by small animals and lost detection of humans. There are three position modes according to mounting height "Low" "Middle" and "High".

### ① Low position mode :

When the sensor is mounted between a height of 6.6' to 8.3' (2.0 to 2.5m).

### ② Middle position mode :

When the sensor is mounted between a height of 8.3' to 11.5' (2.5 to 3.5m).

### ③ High position mode :

When the sensor is mounted between a height of 11.5' to 13' (3.5 to 4.0m).

When the mounting height is 8.3'(2.5m), Low or Middle position is selectable.

When the mounting height is 11.5'(3.5m), Middle or High position is selectable.

Operation mode	Installation height	Detection distance
Low position mode	6.6' to 8.3' (2.0 to 2.5m)	135' (40m)
Middle position mode	8.3' to 11.5' (2.5 to 3.5m)	115' (35m)
High position mode	11.5' to 13' (3.5 to 4.0m)	100' (30m)
High density mode	6.6' to 20' (2.0 to 6.0m)	150' (45m)

\* When the unit operates with anti-masking function ON, mount it at least 1ft. (30cm) away from any adjoining wall / surface to avoid unexpected reflection.

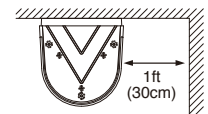

## ● Specialized operation mode

This is operation setting to extremely reduce the lost detection in detection area.

### ④ High density mode

Mounting height is 6.6" to 20' (2.0 to 6.0m).

The mode setting can be selected from above ①~④ modes. (Refer to "7 FUNCTION")

## ■ Mounting method

1. Loosen the cover locking screw and remove the cover unit.



2. Insert the wire through the grommet in the wiring hole at the bottom of the sensor unit. Break the mounting hole knockout of the sensor unit and mount using the supplied tapping screws.

\* Adjust mounting height of the sensor using the center of the sensor unit as a guide.

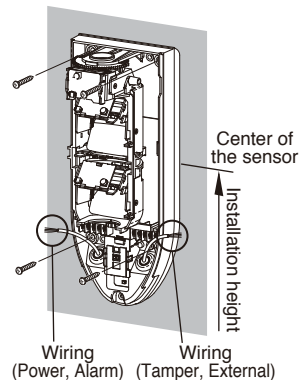

4. Set the detection area and functions according to the installation site. (Refer to "4 DETECTION AREA", "7 FUNCTION", and "8 ADJUSTMENT OF DETECTION")

5. Replace the cover unit, and fix it by tightening the cover locking screws.

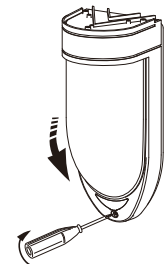

! Insert the wires for power input and alarm output through the wiring hole on the left, and for tamper output and starting output on the right. Be careful not to cross the wires.

\* For open wiring, break the knockout on the rear side of the sensor unit, and pull the wire through it.

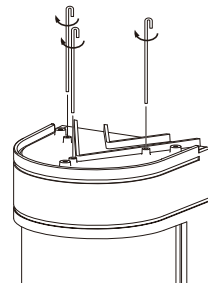

\* When installing outdoors, mount the anti bird spike above the cover unit. Turn the anti bird spike and tighten it.

3. Connect the wires to each terminal. (Refer to "6 WIRING")

6. When the detection area and functions settings are completed, go to section "9 OPERATION CHECK".

### When mounting on the pole [Use the pole attachment]

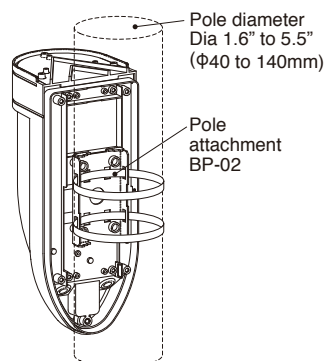
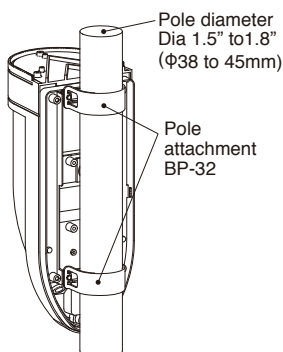

When mounting the unit on a vertical pole, use the pole attachment (sold separately). The unit can be mounted on poles of Dia 1.5" to 1.8" (φ 38 to φ 45mm) and Dia 1.6" to 5.5" (φ 40 to φ 140mm).

\* Mount the sensor so that its mounting surface is positioned vertically.

### When mounting on the ceiling or under eaves [Use the ceiling attachment]

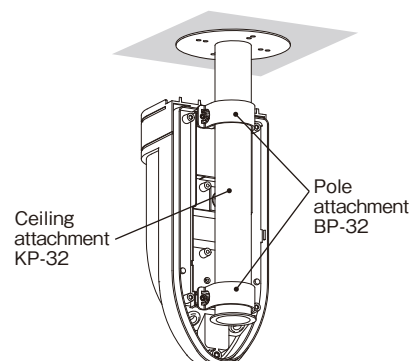

When mounting on the ceiling or under eaves, use the ceiling attachment (sold separately).

\* Mount the sensor so that its mounting surface is positioned vertically.

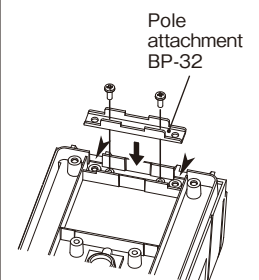

When using the pole attachment BP-32 (sold separately), break the knockout on the rear side of the sensor unit, and attach it.

# 6 WIRING

## Terminal configuration

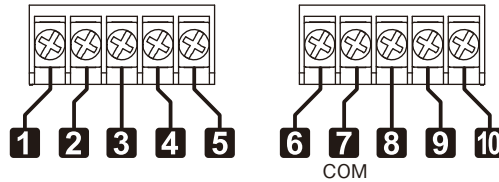

**1 2** Power input (non-polarity)  
9 to 28V DC/Max. 50mA

**3 4** Alarm output  
Contact method : Dry semi-conductor contact, N.O./N.C. selectable  
Contact operation : One-shot operation (2 sec.) when detecting intrusion  
Continuous output in the event of cover monitor error (until detection operation after the cover is closed)  
Continuous output in the event of self diagnosis error (until normal recovery)  
Continuous output in the event of power voltage error (until normal recovery)  
Continuous output in the event of long-term diagnosis error (until the cover is open)  
Continuous output in the event of area checker position error (until normal recovery)  
Contact rating : 24V (AC/DC) 0.25A (resistive load)  
(built-in contact protective resistor 3.3Ω)

**5** LED control input (L/C)  
Control lighting on/off of the alarm LED  
Connect to the positive side of the power supply

**6 7** Anti-masking output  
Contact method : Dry semi-conductor contact N.C.  
Contact operation : Continuously output when an object is placed in front of the lens (until normal recovery)  
Contact rating : 24V (AC/DC) 0.25A (resistive load)  
(built-in contact protective resistor 3.3Ω)

**7 8** Tamper output  
Contact method : Dry mechanical contact, N.C.  
Contact operation : Continuously output when the cover is open (until the cover is closed)  
Contact rating : 24V (AC/DC) 0.1A (resistive load)  
(built-in contact protective resistor 3.3Ω)

**9 10** External output  
Contact method : Dry semi-conductor contact N.O.  
Contact operation : One-shot operation (2 sec.)/Off delay operation (2+30 sec.)  
selectable when detecting intrusion  
\* Each event output is issued as alarm output.  
Contact rating : 24V (AC/DC) 0.25A (resistive load)  
(built-in contact protective resistor 3.3Ω)

## Standard connection

(Connection examples when using two units)

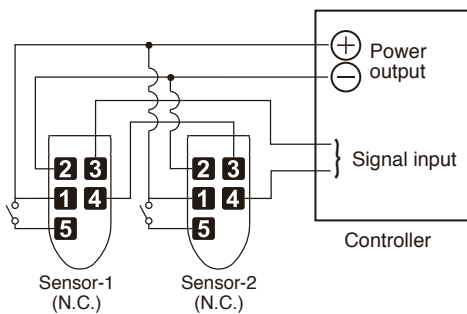

### LED CONTROL FUNCTIONS

Connect terminal ⑤ through an external contact switch with power (+)

#### OPERATION

Turn the DIP switch 1 in Mode selector ① OFF  
When the switch is turned ON, the alarm LED lights at alarm.  
When the switch is turned OFF, the alarm LED does not light.

### Wiring distance between sensor and power supply

	Supply Voltage 12V DC	Supply Voltage 24V DC
AWG20 (Dia 0.8mm)	2,200ft ( 670m)	11,000ft (3,350m)
AWG18 (Dia 1.0mm)	3,500ft (1,070m)	17,500ft (5,340m)
AWG17 (Dia 1.1mm)	4,300ft (1,310m)	21,500ft (6,550m)
AWG16 (Dia 1.25mm)	5,500ft (1,650m)	27,500ft (8,380m)

\* When 2 or more units are connected, the wiring distance is calculated by dividing above value by number of units

# 7 FUNCTION

## Function

### Area checker

This function can be used to visually check the sensitive zone in the detection area by lighting the LED equipped inside the mirror unit.

### Self diagnosis

This function is used to monitor errors with detection elements or sensor circuits, and damaged/disconnected wiring. If damage or disconnection occurs, alarm will be issued using alarm output and alarm LED. Reset the power of the sensor during alarm to stop it. After warming-up operation finishes, monitoring will start again. When an alarm is issued, check the sensor operation immediately.

### Low voltage monitoring

This function is used to issue an alarm when the power voltage level supplied to the sensor decreases abnormally (to approx. 8.5V or less).

Alarm is issued using alarm output and alarm LED before the sensor operation becomes unstable.

It works even during the warming-up operation.

When the power voltage level returns to normal during an alarm, the warning automatically stops. When an alarm is issued, check the power voltage immediately.

### Area checker position monitoring

This function is used to issue an alarm using alarm output and alarm LED when the area checker unit equipped inside the mirror unit has not returned to the original position.  
(Refer to "8 ADJUSTMENT OF DETECTION AREA")

### Tamper

This function is used to monitor the status of the cover unit, attached or removed and issue an alarm against vandalism. If the cover unit is removed, or improperly mounted, alarm will be issued by tamper output. When the cover is attached normally, alarm stops. When an alarm is issued, check the sensor operation immediately.

### Cover monitoring

In addition to the standard tamper, this function will latch the alarm if the cover is opened and will only reset after two activations. This means if the unit is opened and sabotaged whilst the system is disarmed, the panel will report an alarm condition when the system is set.

\* After the cover has been opened/closed for setting or inspection, make the sensor activate twice or more to reset an alarm.

## Temperature compensation

This function is used to automatically adjust the detection sensitivity based on the temperature around the sensor.

## Anti-masking

This function is used to warn against any attempt to circumvent detection such as placing a shielding material over the cover unit. When the masking of the cover unit is detected after a certain time (30~60sec.), the anti-masking alarm will output and alarm LED indicator is lit.

## Description of mode selector

Use the mode selectors 1 and 2 inside the sensor unit for various settings.

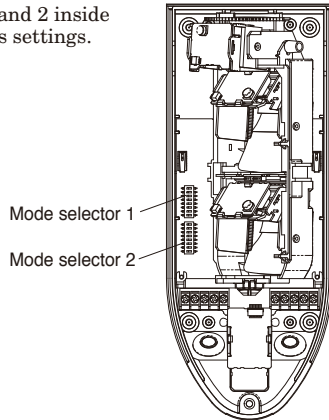

## Mode selector 1

### Alarm LED setting (1 of mode selector 1)

Sets the alarm LED (red) to light on/off.

ON : Enables lighting  
OFF: Light is always off  
Indicates abnormal output only.

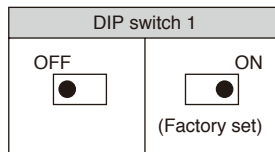

### Memory function setting (2 of mode selector 1)

Sets the memory function to be enabled/disabled.

ON : Enabled  
Sets the lighting operation pattern at 2 of mode selector 2.  
OFF: Disabled

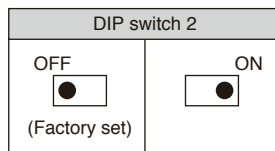

### Sensitivity setting (3 of mode selector 1, 4 of mode selector 1)

Sets detection sensitivity.

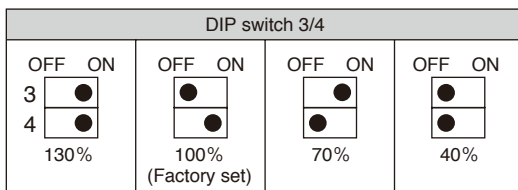

- [130%] Select this option when the temperature of detection targets is low, or the temperature difference between the background and the targets becomes small, for example, in summer.
- [100%] Factory default setting.
- [70%] Select this option when heat sources besides detection targets are often detected with the sensitivity setting at 100%. However, if the temperature difference between detection targets and the background is small, they may not be detected. Make sure to check if detection targets can be detected.
- [40%] Select this option when heat sources besides detection targets are often detected with the sensitivity setting at 70%. However, if the temperature difference between detection targets and the background is small, they may not be detected. Make sure to check if detection targets can be detected.

Check the surface and inside of the sensor unit to confirm that there are no masking objects in front of the sensor and that the sensor operates normally.

After ten seconds following removal of shielding material, anti-masking alarm stops and the sensor recovers after alarm is activated twice.

After replacement of the cover, or during the warming up period, the anti-masking alarm is not output for a certain period of time. If objects such as blot or insect become attached to the surface of cover, the anti-masking alarm may be activated.

Please note that certain shielding material may not be detected such as clear spray, or material with low reflectivity to near-infrared.

### Environmental adjustment setting (5 of mode selector 1)

Sets when false operations frequently occur.

ON : Enabled  
OFF: Disabled

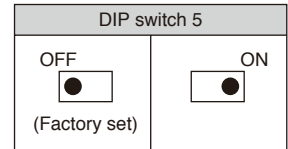

### Operation mode setting (6 and 7 of mode selector 1)

Sets based on the sensor operation mode.

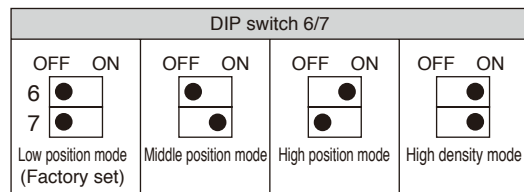

- Low position mode : Select when the installation height is 6.6' to 8.3' (2.0 to 2.5m.)
- Middle position mode: Select when the installation height is 8.3' to 11.5' (2.5 to 3.5m.)
- High position mode : Select when the installation height is 11.5' to 13' (3.5 to 4.0m.)
- High density mode : Select when the installation height is high, or you need to detect objects more accurately.  
(False alarm may increase for outdoor use)

### Creep zone detection setting (8 of mode selector 1)

This setting can be used to detect objects passing in the area directly beneath the walls. Note that pet immunity performance decreases when this setting is enabled. In the specialised operation (high density mode), this setting is disabled.

ON : Enabled  
OFF: Disabled

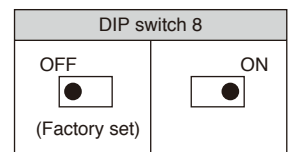

## Mode selector 2

### Walk test setting (1 of mode selector 2)

This setting is used to light up only for a certain period of time even if the alarm function setting (switch 1-1) is disabled. Lighting can be turned ON while the power timer (during warming-up) is on and the following 5 minutes, and for 5 minutes after the cover is closed.

ON : Enabled  
OFF: Disabled

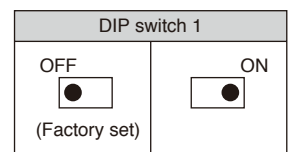

### Memory LED operation setting (2 of mode selector 2)

This setting is used to set the blinking operation of the memory LED (red). This can be set only when DIP switch 2 of mode selector 1 [memory LED setting] is ON.

ON :When the sensor triggers an alarm, the memory LED blinks for 3 minutes, and lights for 47 minutes, then the light goes off. (When the sensor triggers an alarm again during lighting, the timer will be triggered, and the LED will stay lit for a further 47 minutes)

OFF:When the sensor triggers an alarm, the memory LED blinks for 50 minutes, and the light goes off. (When the sensor triggers an alarm again during blinking, the timer will be triggered, and the LED will continue to blink for a further 50 minutes)

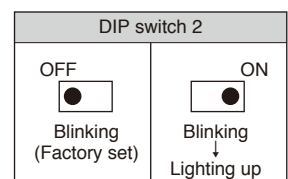

### Alarm contact output changeover setting (3 of mode selector 2)

This setting can be used to select the alarm output logic N.C. or N.O. contact.

ON : N.O.  
OFF: N.C.

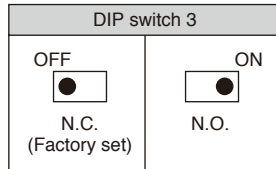

### Output for external device setting (4 of mode selector 2)

This setting can be used to set the output time of external output.

ON : Off-delay (2+30 sec.)  
(When the sensor triggers an alarm again during off-delay time, the timer will be reset, and the unit will continue to output for another 30 seconds)  
OFF: One-shot (2 sec.)

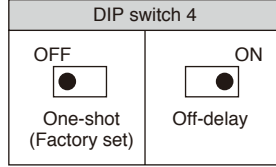

### Short detection distance setting (5 of mode selector 2)

When the detection distance is less than 66'(20m), set "ON".

ON : Enabled  
OFF: Disabled

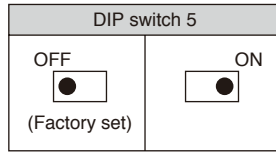

### Anti-masking setting (7 of mode selector 2)

Enable / Disable the anti-masking function.

ON : Enabled  
OFF : Disabled

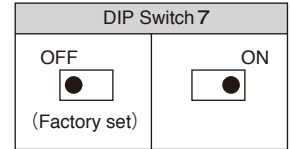

### Factory set

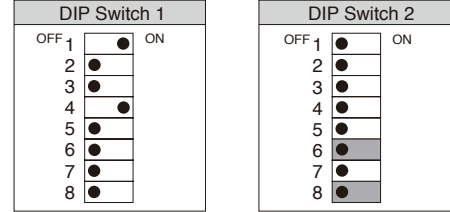

\* Keep the setting OFF in 6, 8 of mode selector 2 for operation.

## Description of LED operation

### Alarm LED operation

- Lights up (for approx. 2 sec.) → When detecting intrusion (lights up for approx. 2 seconds simultaneously with alarm output)
- Continuously lit → Area checker position error (ends when the area checker position is reset)  
Power voltage error (lights up after a power voltage error is detected, and ends when power voltage returns to normal, or the power is reset)

- Blinks (for approx. 1 min.)...

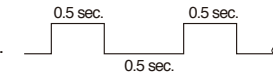

→ During warming-up (blinks for approx. 1 minute after the power is turned ON)

- Continuously blinks (1)

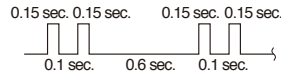

→ Cover monitor error (starts blinking after opening the cover and closing it, and ends when the sensor operates detection twice after a lapse of 10 seconds)  
Anti-masking error (start blinking when the anti-masking error is detected and stops when the sensor operates detection twice after ten seconds following recovery.)

- Continuously blinks (2)...

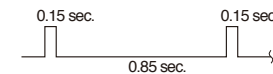

→ Self diagnosis error (starts blinking when a self diagnosis error is detected, and ends when the unit is normally recovered, or the power is reset)

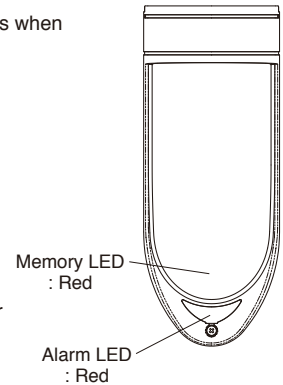

### Memory LED operation

- Blinks for 3 minutes, and then is lit for 47 minutes...

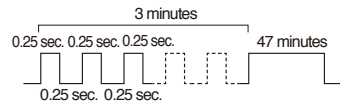

→ When memory is indicated [auto reset operation: light goes off after blinking for 3 minutes, and then is lit for 47 minutes] (retrigger enabled during lighting)

- Blinks for 50 minutes...

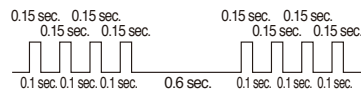

→ When memory is indicated [auto reset operation: light goes off after blinking for 50 minutes] (retrigger enabled during lighting)

- Continuously blinks...

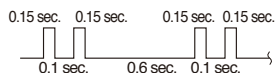

→ Cover monitor error (blinking for 10 seconds after opening the cover and closing it)



# 8 ADJUSTMENT OF DETECTION AREA

## Detection area adjustment method

- The detection area and detection operation can be optimized as follows:
- Operating the area selector enables adjustment to the distance of the detection area.
- Turning the mirror unit enables the user to adjust the detection area in a horizontal direction.

### AREA SELECTOR

		DETECTION DISTANCE						LOW, MID, HIGH MODE
		66ft (20m)	83ft (25m)	100ft (30m)	115ft (35m)	135ft (40m)	150ft (45m)	
INSTALLATION HEIGHT	6.6ft (2m)	A/B	A/B	A/B	A	A	—	
	8.3ft (2.5m)	B	A/B	A/B	A/B	A/B	—	
	10ft (3m)	B/C	B	B	A/B	—	—	
	11.5ft (3.5m)	B/C	B/C	B	B	—	—	
	13ft (4m)	C	B/C	B/C	—	—	—	

		DETECTION DISTANCE						HIGH DENSITY MODE
		66ft (20m)	83ft (25m)	100ft (30m)	115ft (35m)	135ft (40m)	150ft (45m)	
INSTALLATION HEIGHT	6.6ft (2m)	B	A/B	A/B	A/B	A/B	A/B	
	8.3ft (2.5m)	B	B	A/B	A/B	A/B	A/B	
	10ft (3m)	B/C	B	B	A/B	A/B	A/B	
	11.5ft (3.5m)	C	B/C	B	B	A/B	A/B	
	13ft (4m)	C/D	C	B/C	B	B	B	
	15ft (5m)	D	C/D	C	B/C	B/C	B/C	
20ft (6m)	E	D	C/D	C	C	B/C		

When the detection area is adjusted to less than 66'(20m), adjust it using supplied area masking sheet and set "ON" in the short distance setting (dip switch 5 in mode selector 2)  
(Refer to "4 DETECTION AREA", "7 FUNCTION")

[Example 1] Low position mode  
Mounting height : 6.6'(2m)  
To set the maximum distance to 115'(35m) :  
Choose area selector [A]

[Example 2] Middle position mode  
Mounting height : 10'(3m)  
To set the maximum distance to 66'(20m) :  
Choose area selector [B/C]

[Example 3] High position mode  
Mounting height : 20'(6m)  
To set the maximum distance to 135'(40m) :  
Choose area selector [C]

### Detection distance adjustment

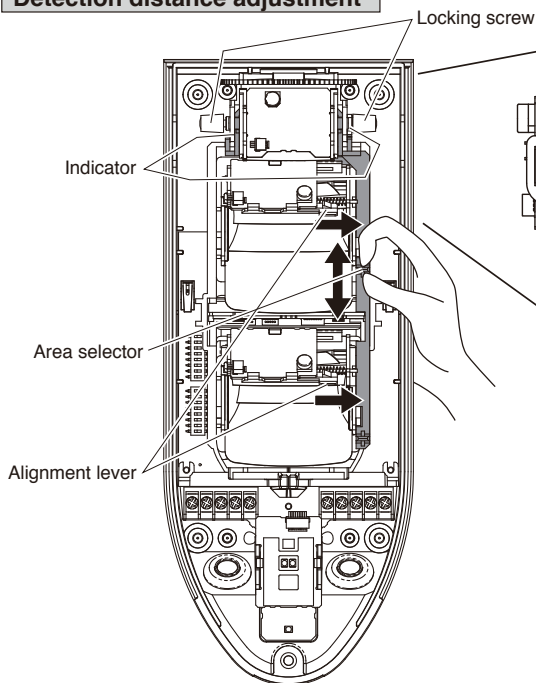

Locking screw can be tightened both from left and right, but the tightening direction is different.  
Tighten the screw as indicated on the plate.

### Detection distance [rough adjustment]

Refer to the area setting table inside the sensor unit, and set the detection area corresponding to the installation site using the area selector and indicator. Then tighten the locking screw. (When moving the area selector up and down, the indicator will show the letters from A to E. Select the position based on the installation height and maximum detection distance.)

[Example] Middle position mode  
Mounting height : 10'(3m)  
To set the maximum distance to 100'(30m) :  
Choose area selector [B]

### Detection distance [fine adjustment] using LED area checker

To enable fine adjustment mode slide the two alignment levers to the right and latch into place, this will activate the alignment LEDs. Look at the sensor to check the sensitive zones, the mirror surfaces will appear red or green when standing inside the detection area. Use the horizontal direction adjustment to fine-tune as required.

Stand at the maximum distance of your desired coverage and adjust the area selector so that the red mirror surface is visible between shoulder and chest height, and the green mirror surface is visible between waist and knee height.

Note: the mirror surfaces will appear unlit when standing outside of the detection area.

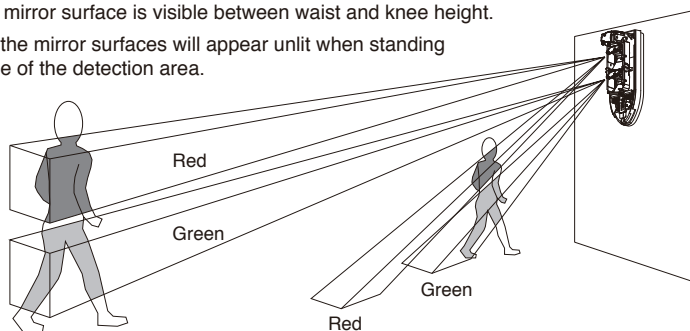
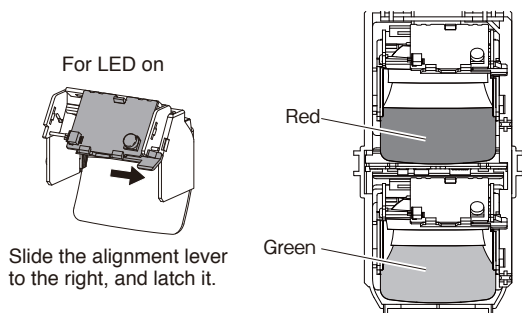

When the zone faces toward a place where false operation can occur (refer to "3 PRECAUTIONS"), adjust or mask the area to avoid.

### Horizontal direction adjustment

Turn the mirror unit to the direction you want to protect to adjust the detection area.  
(±45° adjustable [in 5° steps])

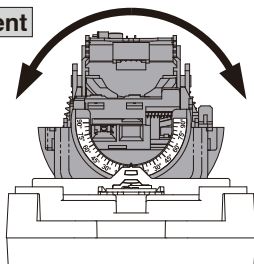

When the adjustment has been completed unlatch both alignment levers and ensure they return to the left edge of each mirror unit. If the levers are not returned to the original position the unit will issue a continuous alarm output and the alarm LED will illuminate.

For LED off

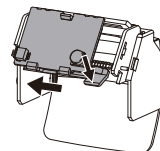

Unlatch the alignment lever and return to its original position

# 9 OPERATION CHECK

1. When the power is turned ON, the alarm LED (red) starts blinking, which shows warm up status. Wait approximately 1 minute until blinking ends. (No blinking operation when the alarm LED is set to OFF) The unit does not issue alarm during warm up.
2. After the LED stops blinking, walk across the detection area. Check that the alarm LED lights up. Close the cover and walk across the detection area, and check operation on both the sensor (LED) and connected device (controller).

\* When the alarm LED is set to OFF for operation, use the walk test function and check operation.

# 10 TROUBLESHOOTING

If the unit does not operate properly, refer to the following table and check the unit.  
If the unit cannot be restored to normal operation after checking, contact the dealer or TAKEX.

Status	Cause	Remedy
Unit does not operate at all	<ol style="list-style-type: none"> <li>(1) Power is not turned ON (including cable disconnection), or the power voltage is too low.</li> <li>(2) Approximately 1 minute has not passed since the power is turned ON (The alarm LED is blinking)</li> <li>(3) There are shielding objects in front of the detection area (Note that glass is considered as a shielding object)</li> <li>(4) Detection area setting is inappropriate</li> </ol>	<ol style="list-style-type: none"> <li>(1) Check the power wire and set the power voltage properly</li> <li>(2) Wait approximately 1 minute</li> <li>(3) Remove shielding objects</li> <li>(4) Set the detection area again</li> </ol>
Unit does not operate from time to time	<ol style="list-style-type: none"> <li>(1) Detection area setting is inappropriate</li> <li>(2) Cover surface is dirty with dust or water</li> <li>(3) Detection distance is inappropriate</li> <li>(4) Temperature difference between the human body and surrounding area is small</li> </ol>	<ol style="list-style-type: none"> <li>(1) Set the detection area again</li> <li>(2) Wipe off dirt using a soft, dry cloth (Do not use any chemicals, such as thinner or benzine, which may result in damage to the unit)</li> <li>(3) Set the detection distance within the rated distance (Maximum detection distance: 150'(45m), mounting height: between 6.6' to 20'(2.0 to 6.0m))</li> <li>(4) Set the sensitivity setting to 130%</li> </ol>
Unit operates when no human body passes through the area	<ol style="list-style-type: none"> <li>(1) Power voltage is unstable</li> <li>(2) There are moving objects (such as pets), or equipment subject to rapid temperature fluctuations (such as air outlets or outdoor units of air-conditioning equipment, refrigerator, or clothes dryer)</li> <li>(3) There are sources to generate electric noise</li> <li>(4) Unit is subject to strong sunlight reflection or headlights</li> <li>(5) Unit detects human bodies passing outside the detection area</li> <li>(6) Sensitivity setting is high</li> <li>(7) Unit detects pets</li> <li>(8) Unit detects an automatic cleaning robot</li> </ol>	<ol style="list-style-type: none"> <li>(1) Set the power voltage properly</li> <li>(2) Remove objects causing the trouble</li> <li>(3) Change the mounting place</li> <li>(4) Change the mounting place, or shield the light using shades</li> <li>(5) Set the detection area again</li> <li>(6) Set the sensitivity setting to 70% or 40%</li> <li>(7) Keep pets away from the detection area</li> <li>(8) Keep automatic cleaning robots away from the detection area</li> </ol>
Alarm LED lights up, but the connected device does not operate	<ol style="list-style-type: none"> <li>(1) Alarm signal is not transmitted properly, or wiring is disconnected or short-circuited</li> <li>(2) Alarm contact output is not issued</li> <li>(3) Alarm output setting is inappropriate</li> <li>(4) Connected devices do not operate properly</li> </ol>	<ol style="list-style-type: none"> <li>(1) Fix poor wiring, disconnection, and short-circuit</li> <li>(2) Use a tester and check the output terminals</li> <li>(3) Change the alarm output setting</li> <li>(4) Check connected devices</li> </ol>
Alarm LED continues to light or blink, and the alarm goes on continuously (Abnormal detection)	<ol style="list-style-type: none"> <li>(1) Check if the abnormal detection status is generated after warming up even if the power is reset</li> </ol>	<ol style="list-style-type: none"> <li>(1) Disconnection or damage may occur inside the unit</li> </ol>

### Daily inspection

- For maintenance, wipe the unit clean using a soft, wet cloth, and wipe off any water. If the unit is seriously dirty, lightly wipe the unit clean using a soft cloth that has been immersed in water diluted neutral detergent, and the wipe off the detergent completely. Do not use thinners or benzine. (Otherwise plastic components may become deformed, discolored, or changed)
- Check operation periodically, approximately every week. Also make sure to check operation when you move tables and partitions and change the layout in protected rooms.

# 11 SPECIFICATIONS

Model	Triple mirror passive sensor
Model number	PIR-T40NAM (W)
Detection system	Passive infrared
Detection area	Vertical curtain protection Detection distance : Max 150' (45m), 46 rays (23 pairs)
Power supply	9 to 28V DC (non-polarity)
Current consumption	Max. 50mA
Alarm output	Contact method : Dry semi-conductor contact, N.C./N.O. selectable Contact operation : One-shot operation when detecting intrusion Continuous output in the event of cover monitor error Continuous output in the event of alignment position error Continuous output in the event of self diagnosis error Continuous output in the event of power voltage error Contact rating : 24V (AC/DC) 0.25A (resistive load) (built-in contact protective resistor 3.3Ω)
External output	Contact method : Dry semi-conductor contact N.O. Contact operation : One-shot operation / Off delay operation selectable when detecting intrusion Contact rating : 24V (AC/DC) 0.25A (resistive load) (built-in contact protective resistor 3.3Ω)
Tamper output	Contact method : Dry mechanical contact, N.C. Contact operation : Continuous output Contact rating : 24V (AC/DC) 0.1A (resistive load) (built-in contact protective resistor 3.3Ω)
Anti-masking output	Contact method : Dry semi-conductor contact N.C. Contact operation : Continuously output when an object is placed in front of the lens (until normal recovery) Contact rating : 24V (AC/DC) 0.25A (resistive load) (built-in contact protective resistor 3.3Ω)
Alarm LED	Red LED : Blinks* during warm up Lights up* when detecting intrusion Continuously blinks in the event of cover monitor error Continuously lit in the event of alignment position error Continuously blinks in the event of self diagnosis error Continuously lit in the event of power voltage error Continuously blinks in the event of Anti-masking error (* ON/OFF selectable using the mode selector)
Memory LED	Red LED : Blinks for 3 minutes during memory display, Auto reset operation either of continuous lighting for 47 minutes or blinking for 50 minutes selectable (Blinks to lights / blinks, ON/OFF selectable using the mode selector)
Functions	Sensitivity selection Operation mode selection Alarm memory LED Self diagnosis Low voltage monitoring Temperature compensation Front & back tamper LED area checker Environmental adjustment Creep zone detection Walk test mode Near area cancellation Anti-masking
Mounting height	6.6' to 20' (2.0 to 6.0m) (varies depending on the operation mode) • Low position mode : 6.6' to 8.3' (2.0 to 2.5m) (Maximum detection distance : 135' (40m)) • Middle position mode : 8.3' to 11.5' (2.5 to 3.5m) (Maximum detection distance : 115' (35m)) • High position mode : 11.5' to 13' (3.5 to 4.0m) (Maximum detection distance : 100' (30m)) • High density mode : 6.6' to 20' (2.0 to 6.0m) (Maximum detection distance : 150' (45m))
Area angle adjustment range	Horizontal direction : ±90° (in 5° steps) Vertical direction : 17° (no stage adjustment)
Ambient temperature range	-25 to +55°C (no condensation and freezing)
Mounting position	Indoor / outdoor wall surface * Can be mounted on poles and ceilings (or under eaves) using optional accessories
IP rating	IP55
Connections	Terminals (M2.6 self up terminal)
Weight	Approx. 600g
Appearance	Body : Resin (white), Window : Resin (white)

# 12 EXTERNAL DIMENSIONS Unit: inch (mm)

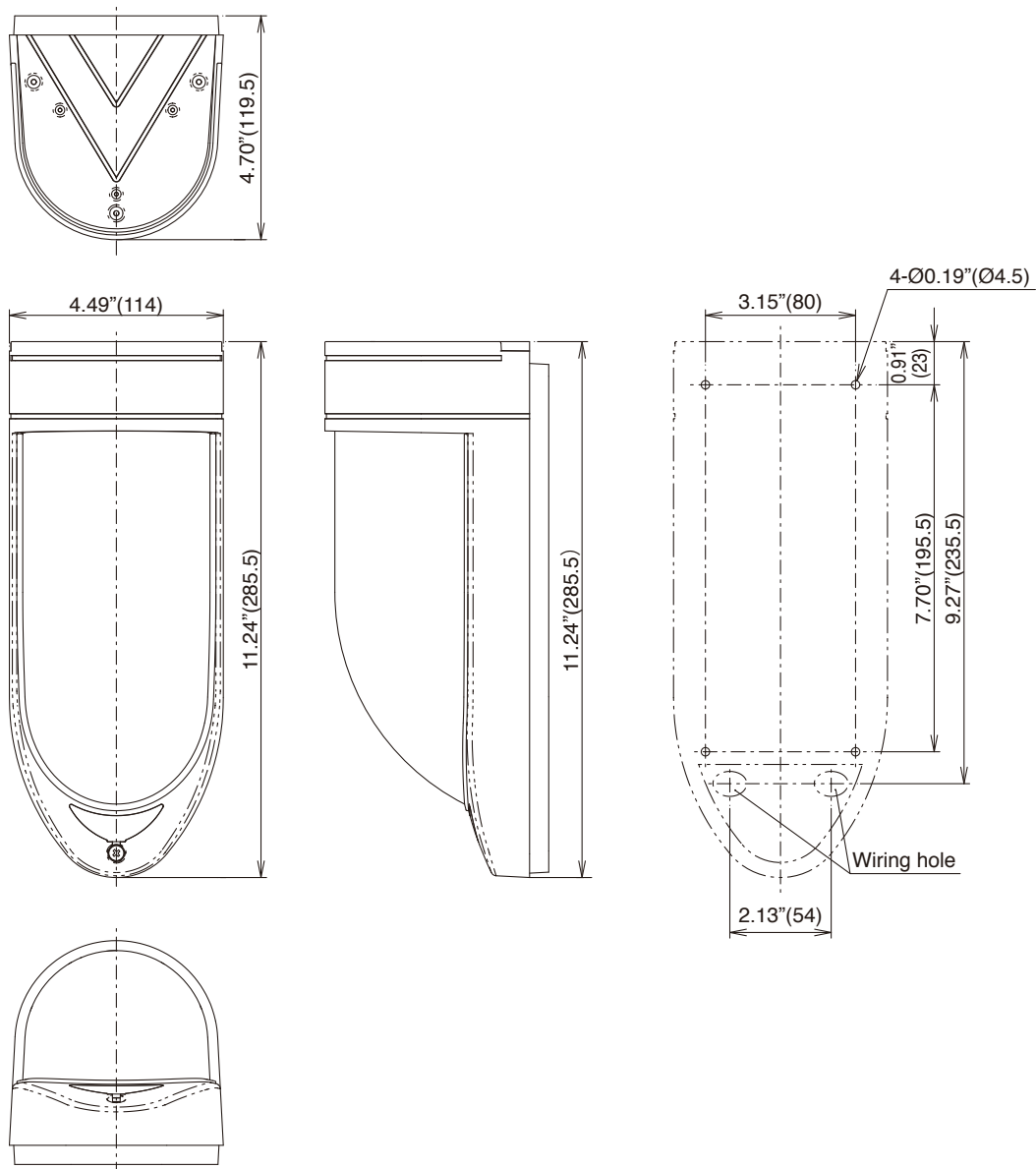

- Options : Pole attachment      BP-32
- Pole attachment      BP-02
- Ceiling attachment      KP-32

## Limited Warranty :

TAKEX products are warranted to be free from defects in material and workmanship for 12 months from original date of shipment. Our warranty does not cover damage or failure caused by natural disasters, abuse, misuse, abnormal usage, faulty installation, improper maintenance or any repairs other than those provided by TAKEX. All implied warranties with respect to TAKEX, including implied warranties for merchantability and implied warranties for fitness, are limited in duration to 12 months from original date of shipment. During the Warranty Period, TAKEX will repair or replace, at its sole option, free of charge, any defective parts returned prepaid. Please provide the model number of the products, original date of shipment and nature of difficulty being experienced. There will be charges rendered for product repairs made after our Warranty Period has expired.

## **TAKEX TAKENAKA ENGINEERING CO., LTD.**

**In Japan**  
**Takenaka Engineering Co., Ltd.**  
 83-1, Gojo-sotokan,  
 Higashino, Yamashina-ku,  
 Kyoto 607-8156, Japan  
 Tel : 81-75-501-6651  
 Fax : 81-75-593-3816  
<http://www.takex-eng.co.jp/>

**In the U.S.**  
**Takex America Inc.**  
 151 San Zeno Way  
 Sunnyvale,  
 CA 94086, U.S.A  
 Tel : 408-747-0100  
 Fax : 408-734-1100  
<http://www.takex.com>

**In Australia**  
**Takex America Inc.**  
 4/15 Howleys Road, Notting Hill,  
 VIC, 3168  
 Tel : +61 (03) 9544-2477  
 Fax : +61 (03) 9543-2342

**In the U.K.**  
**Takex Europe Ltd.**  
 Takex House, Aviary Court, Wade Road,  
 Basingstoke, Hampshire. RG24 8PE, U.K.  
 Tel : (+44) 01256-475555  
 Fax : (+44) 01256-466268  
<http://www.takexurope.com>